



DIAMOND C-30A (9.3 μm)

Air-Cooled RF-Excited OEM Industrial CO₂ Laser

Features

- Ultra-compact
- Outstanding beam quality
- Excellent power stability
- Single, integrated package
- Cost-saving and simple, direct-air cooling
- Linear polarization
- Low-cost OEM configuration
- Fast rise/fall time
- All-metal seals for long life
- Wide operating power range
- CW or modulated up to 25 kHz

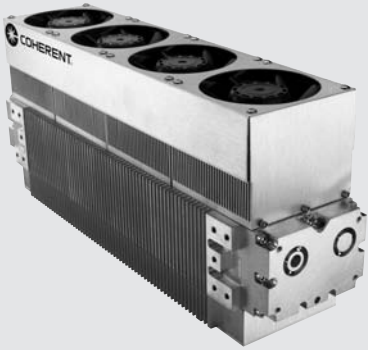

Mechanical Specifications

Laser Head

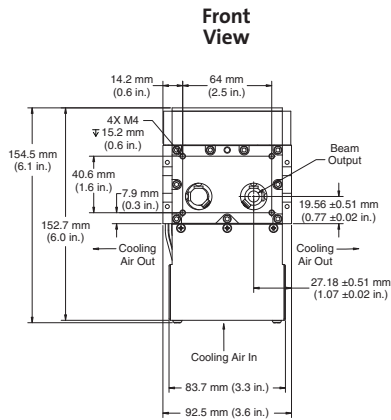

Top View

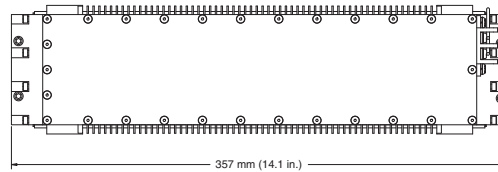

Side View

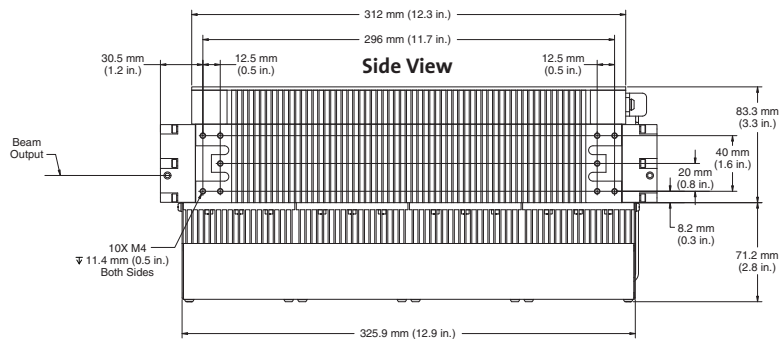

Rear View

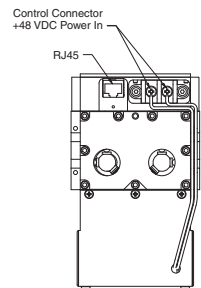

Bottom View

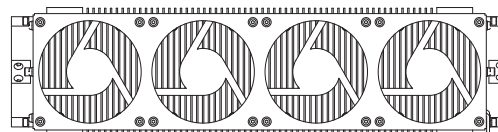

Superior Reliability & Performance

DIAMOND™ C-30A (9.3 μm)

Air-Cooled RF-Excited OEM Industrial CO₂ Laser

System Specifications

Wavelength (μm)	9.24 to 9.35
Optical Output Power ¹ (W)	17
Power Stability ² (%)	±5
Mode Quality (M ²)	<1.2
Beam Size (mm)	1.8 ±0.2
Beam Divergence (mrad, full angle)	7.5 ±0.5
Polarization	>100 to 1 (fixed linear, parallel to width dimension)
Operating Frequency and Duty Cycle	0 to 25 kHz, 0 to 100% DC

Configuration and Facility Requirements

Weight	6.6 kg (14.5 lbs.)
Dimensions (L x W x H)	357 x 92.5 x 154.5 mm (14.1 x 3.64 x 6.08 in.)
Input Power	48VDC ±2% regulation, <±1% P-P noise/ripple, 12A max. avg., with 18A peak for 1 msec. minimum, measured at input terminals
Heat Dissipation (W)	<575
Maximum Case Temperature	<60°C (140°F)
Operating Environment	
Temperature	5 to 40°C (41 to 113°F)
Altitude	<2000 m (6500 ft.)
Humidity	Non-condensing
Shipping/Storage Environment	-10 to 60°C (14 to 140°F), non-condensing

¹ Power measured at 25°C and derated by 1%/C for higher laser head temperatures.

² Power stability based on $\pm(P_{\max} - P_{\min}) / (2 \cdot P_{\max})$ average power measurement at constant duty cycle after 10-minute warmup at operating condition.

Coherent, Inc. guarantees that the output power of the C-30A will exceed the rated power for a period of 24 months, independent of the actual operating time. Coherent, Inc. also warrants to the original purchaser for a period of 24 months from the date of delivery that the C-30A is free from defects in material and workmanship. The warranty does not apply to any unit damaged by accident, abuse or operation in a manner inconsistent with the procedures and specifications outlined in the manual supplied with the laser.

The C-30A is a laser component that does not include all safety features as required by the FDA and the Center for Devices and Radiological Health (CDRH). It is sold solely to qualified manufacturers who in their end product will supply all interlocks and indicators, and will comply fully with CDRH regulations and/or local regulatory agencies.



www.Coherent.com

Coherent, Inc.
 5100 Patrick Henry Drive
 Santa Clara, CA 95054
 phone (800) 527-3786
 (408) 764-4983
 fax (408) 764-4646
 e-mail tech.sales@Coherent.com

Benelux +31 (30) 280 6060
 China +86 (10) 6280 0209
 France +33 (0)1 6985 5145
 Germany +49 (6071) 968 333
 Italy +39 (02) 34 530 214
 Japan +81 (3) 5635 8700
 Korea +82 (2) 460 7900
 UK +44 (1353) 658 833

